

SV. EFFETTIVO 1217X811

PESO : 5.19 KG

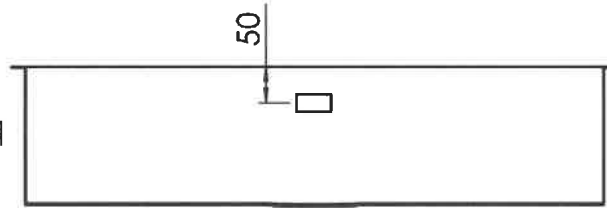

SEZIONE A-A
SCALA 1 : 10

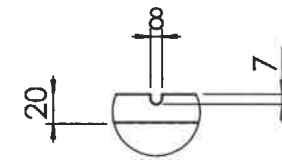
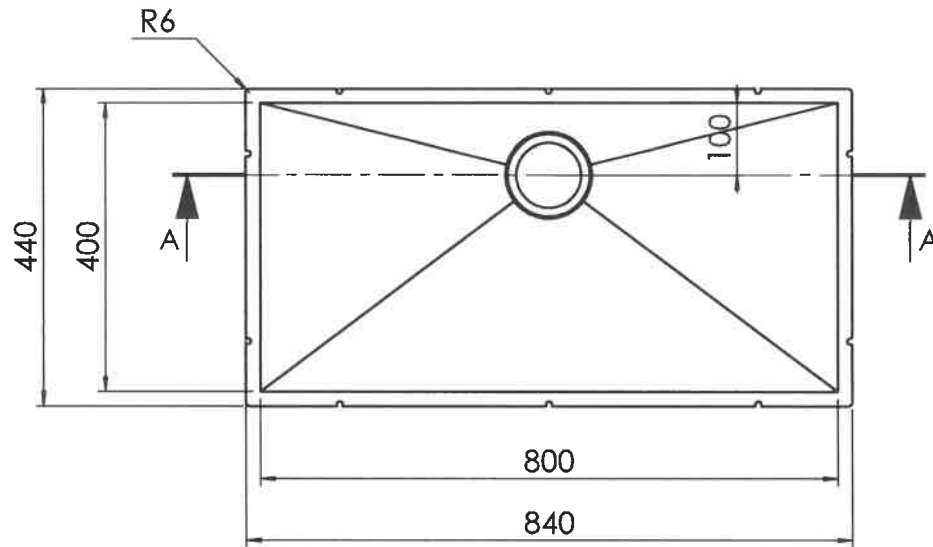

DETTAGLIO B
SCALA 1 : 5

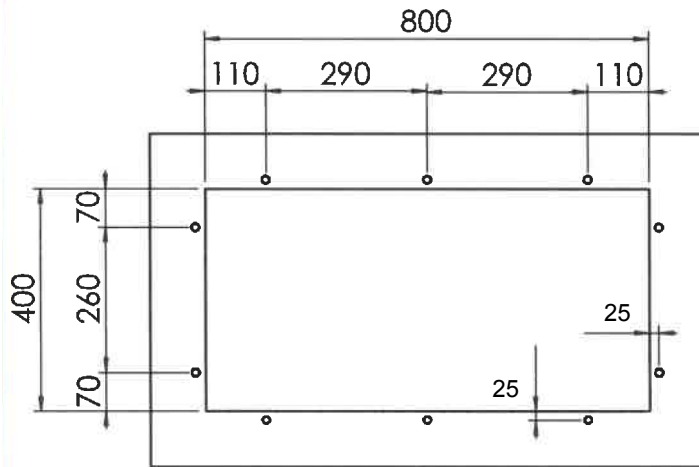
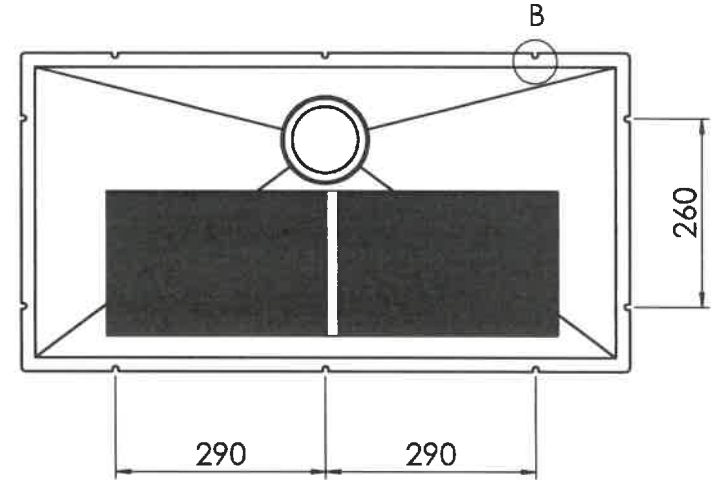

Foratura sottotop
foro sottotop: 800x400
n°10 fori \varnothing 13 mm prof.15 mm
base 900 mm

VITE A MISURA
15 MM
FISSAGGIO VITE-BUSSOLA

ETHNA XXL SOTTOTOP